

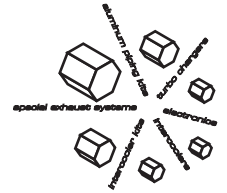

# EBC-R-EVO

ELECTRONIC BOOST BOOST CONTROLLER TYPE R EVO

## OPERATION MANUAL



### INTRODUCTION

HDI ELECTRONIC BOOST CONTROLLER TYPE - R IS SPECIALLY DESIGNED FOR SIMPLE INSTALLATION, EASY OPERATION AND EFFECTIVE FUNCTION. JUST CONNECT THE IGNITION +12V AND EARTH OR SIMPLY PLUG IN OUR OPTIONAL ROCKET ARMING SWITCH PLUG IN KIT (PURCHASE SEPARATELY) AND THE UNIT IS READY FOR ACTION. ITS UNIQUE RETRACTABLE ADJUSTMENT DIAL ADDS EXTRA SAFETY TO PREVENT ACCIDENTAL ADJUSTMENT. AT HDI OUR GOAL IS TO PRODUCE THE BEST PRICED AND VALUE FOR MONEY PERFORMANCE PARTS IN THE MARKET. ALL ELECTRONICS ARE ENCLOSED IN A 1/4DIN RIGID ALUMINUM CASE TO WITH STAND THE TOUGHEST RACING ENVIRONMENTS. NEW ADDED BOOST , SOLENOID MONITORING FUNCTION AND FINE ADJUSTMENT FUNCTION USER CAN EASILY ADJUST AND CHECK FOR OPERATION.

### SPECIFICATIONS

SUPPLY VOLTAGE:	10-16V (POLARITY PROTECTED)	" OPTIONAL AUTOMATIC TURBO TIMER (WITH I-DRIVER) " SUIT ANY TURBOS CONFIGURATION * OPTIONAL FINE ADJUSTMENT DIAL
MAXIMUM BOOST HANDLING:	30 PSI	
MAXIMUM SOLENOID PRESSURE:	100 PSI	
OPERATING TEMPERATURE:	-18 - 60 DEGREE C	
SOLENOID OPERATING TEMPERATURE:	-25 - 85 DEGREE C	
CURRENT CONSUMPTION (STAND BY):	<100 MA	
WASTEGATE TYPE:	INTERNAL OR EXTERNAL	

### PRECAUTIONS

#### Warning

- " ALTHOUGH INSTALLATION OF THIS PRODUCT IS DESIGNED TO BE SIMPLE WE DO RECOMMEND THE INSTALLATION BE CARRIED OUT BY OUR DEALER WITH A QUALIFIED AUTOMOTIVE TECHNICIAN.
- " DISCONNECT THE VEHICLE NEGATIVE BATTERY CABLE BEFORE AND DURING THIS INSTALLATION. OBSERVE ALL ROUTINE SAFETY PRECAUTIONS WHEN WORKING ON OR NEAR THE VEHICLE BATTERY.
- " DO NOT INSTALL THE DEVICE THAT INTERFERE THE DRIVER IN ANY WAY.
- " AVOID CONTACTS BETWEEN ALL METAL OBJECTS AND THE WIRES. SHORT CIRCUIT WILL CAUSE SEVERE DAMAGE TO THE VEHICLE AND TO THE UNIT IT SELF.
- " DO NOT CONNECT IT WITH OTHER NON HDI PRODUCTS THAT ARE NOT IN THIS INSTALLATION DOING SO MAY HARM OR DAMAGE TO THE VEHICLE AND THE DEVICE ITSELF.
- " NEVER PERFORM ADJUSTMENT WHEN DRIVING ON ANY ROAD, DOING SO IS DANGEROUS TO YOURSELF AND TO OTHERS.
- " MAKE SURE ADEQUATE AIR VENTILATION IS EQUIPPED DURING THE INDOOR INSTALLATION.
- " REMOVE ANY OF THE TOOLS USED AFTER THE INSTALLATION.
- " ALL ELECTRONIC CONTROLLER UNITS ARE TO BE USED IN CABIN DO NOT INSTALL IT IN THE ENGINE BAY.

### IMPORTANT

HDI'S PRODUCT IS DESIGN FOR RACING AND OFF-ROAD VEHICLE ONLY NOT FOR PUBLIC ROAD.PLEASE READ THROUGH ALL THE INSTRUCTION AND PRACTICE ALL PRECAUTION IN ALL ASPECT OF SAFETY AND EVERY STEP PRIOR AND DURING THE INSTALLATION. THIS INSTALLATION MENU IS PURELY FOR HDI PRODUCTS AND IS USED AS GUIDE ONLY. AS DIFFERENT VEHICLES IN DIFFERENT COUNTRIES MAY HAVE DIFFERENT SPECIFICATIONS AND ENGINE ARRANGEMENT. THEREFORE, IT IS IMPORTANT TO MAKE SURE THE CONNECTION IS PROPERLY DONE BY AUTHORIZED PERSON AND DEALER. DURING THE INSTALLATION OF THIS PRODUCT, WEAR EYE GOGGLES AND OTHER SAFETY APPAREL AS NEEDED TO PROTECT YOURSELVES FROM THE DIRT AND OTHER SHARP OBJECTS. MAKE SURE THE VEHICLE IS SUPPORTED BY JACK STANDS ON A HARD, LEVEL SURFACE. SET THE VEHICLE PARKING BRAKE IF THE VEHICLE MUST BE RISEN TO OBTAIN THE UNDERCARRIAGE ACCESS AND USE WHEEL CHOCKS AS NECESSARY.

### WARRENTY

HYBRID DEVELOPMENT INTERNATIONAL WILL WARRANTY FOR THE PERIOD OF 1 YEAR FROM ORIGINAL PURCHASE AGAINST ALL DEFECTS IN WORKMANSHIP AND MATERIALS. HYBRID DEVELOPMENT INTERNATIONAL IS NOT RESPONSIBLE FOR EXPENSES INCURRED FOR LABOUR, PERSONAL INJURY OR INCONVENIENCE. HYBRID DEVELOPMENT INTERNATIONAL SOLE RESPONSIBILITY IS TO OFFER A REPLACEMENT PRODUCT OR TO REPAIR THE DAMAGED PRODUCT. HYBRID DEVELOPMENT INTERNATIONAL CANNOT WARRANTY PRODUCTS DAMAGED BY IMPROPER INSTALLATION. ALL OTHER PRODUCTS SOLD BY HYBRID DEVELOPMENT INTERNATIONAL ARE WARRANTED BY THE ORIGINAL MANUFACTURES AND IS NOT THE RESPONSIBILITY OF HYBRID DEVELOPMENT INTERNATIONAL. ALL PRODUCTS ARE FOR RACING USE ONLY. ALL RIGHTS RESERVED.

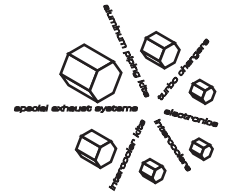

# OPERATION MANUAL

## PARTS LIST

NO.	DESCRIPTION	QUANTITY
1.	HDI-EBC-R MAIN CONTROLLER UNIT	1
2.	HDI 3 WAY SOLENOID WITH PLUG IN HARNESS	1
3.	HDI FIRE RETARDANT SILICON HOSE	1 X 2 METER
4.	T-PIECE CONNECTOR	1
5.	HDI MINI POWER PLUG IN WIRING HARNESS	1
6.	ROCKET ARMING SWITCH PLUG IN KIT	OPTIONAL
7.	CABLE TIGHT	5
8.	DOUBLE SIDED STICKY TAPE	1
9.	FITTING	2

## INSTALLATION GUIDE

1. CONNECT THE SOLENOID ACCORDING TO THE DIAGRAM WITH THE SHORTEST POSSIBLE VACUUM HOSE CONNECTION AND AWAY FROM HEAT PLEASE NOTE SOME EXTRA PARTS MAY NEEDED FOR NON BASIC TURBO CONFIGURATION AND CAN BE PURCHASE FROM [WWW.HYBRID-POWER.COM](http://WWW.HYBRID-POWER.COM).
2. LOCATE A GROMMET HOLE IN THE FIRE WALL AND RUN THE SOLENOID HARNESS AND VACUUM HOSE THROUGH THE HOLE. MAKE SURE YOU CABLE TIE IT AWAY FROM MOVING PARTS, HEAT AND POTENTIAL SHORT CIRCUIT HAZARDS.
3. LOCATE THE HDI EBC-R HEAD UNIT IN A POSITION THAT DOES NOT INTERFERE WITH THE DRIVER AND DO NOT PLACE DIRECTLY IN THE SUN.
4. CLEAN THE SURFACE TO MAKE SURE IT'S FREE FROM OIL, GREASE OR WAX BEFORE AFIXING THE HDI EBC-R HEAD UNIT.
5. SECURE THE HDI-EBC-R MAIN CONTROLLER UNIT WITH PROVIDED DOUBLE SIDED TAPE
6. CONNECT THE POWER SUPPLY HARNESS RED TO IGNITION SWITCHED +12 V (ROCKET ARMING SWITCH PLUG AND PLAY KIT CAN BE PURCHASED OPTIONAL)
7. CONNECT THE VACUUM HOSE (THE ONE THROUGH THE FIREWALL) TO THE BACK OF THE UNIT AND CABLE TIE IT TO PREVENT PRESSURIZED BLOW OUT
8. PLUG IN THE POWER HARNESS AND THE SOLENOID HARNESS WIRE (THE ONE FROM THE FIRE WALL)
9. RECHECK ALL THE CONNECTION AGAIN MAKE SURE ALL VACUUM HOSES ARE CABLE TIGHTEN AND GET READY FOR SETTING THE BOOST UP.

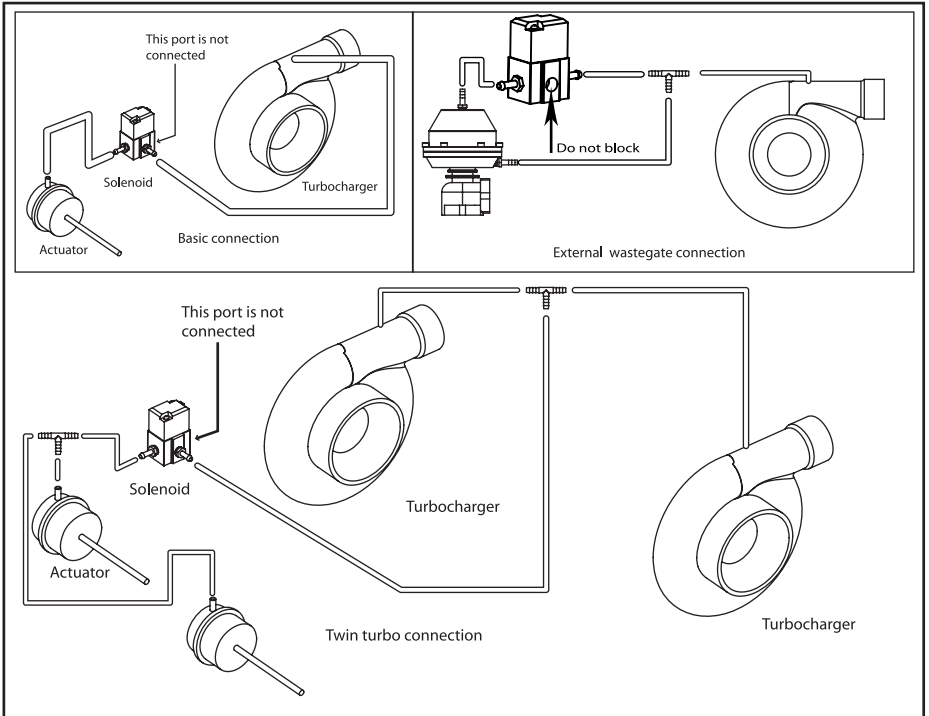
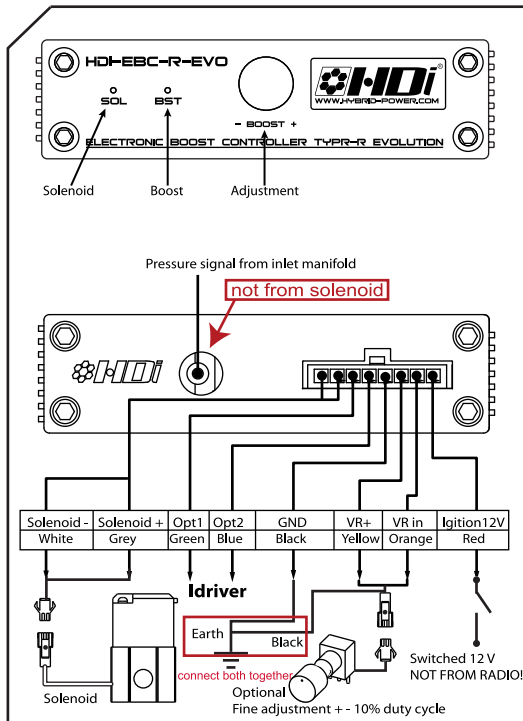

**BASIC CONNECTION : ONLY NEED TO CONNECT 12 V , EARTH , SOLENOID AND MANIFOLD PRESSURE OTHER OPTIONAL PARTS PLEASE EMAIL [SALES@HYBRID-POWER.COM](mailto:SALES@HYBRID-POWER.COM)**

## SETTING THE BOOST

ALTHOUGH SETTING THE HD-EBC-R UP IS EXTREMELY SIMPLE. WE DO RECOMMEND THE SETTING IS DONE ON A DYNO AND WITH A BOOST GAUGE

1. PUSH THE ADJUSTMENT DIAL SO IT EXTENDS OUTWARDS FOR EASY ADJUSTMENT.
2. TURN THE ADJUSTMENT DIAL FULLY COUNTER CLOCKWISE.
3. ON THE DYNO, ENGAGE THE 2ND OR 3RD GEAR AND APPLY LOAD TO THE ENGINE TILL THE BOOST IS STABLE.
4. TURN THE DIAL CLOCKWISE TO INCREASE OR COUNTER CLOCKWISE TO DECREASE THE BOOST.
5. REPEAT THE ABOVE STEP 3 AND STEP 4 IF NEEDED FOR READJUSTMENT TILL THE DESIRE BOOST IS SET
6. AFTER DESIRE BOOST LEVEL IS REACHED PUSH THE ADJUSTMENT DIAL AGAIN SO IT IS RETRACTED TO AVOID UNWANTED ACCIDENTAL ADJUSTMENT.